

Sentiment Analysis Accuracy for 2024 Indonesian Election Tweets Using CNN-LSTM With Genetic Algorithm Optimization

Received:
3 July 2024
Accepted:
31 August 2024
Published:
23 February 2025

^{1*}Athallah Zacky Abdullah, ²Erwin Budi Setiawan
^{1,2}*Informatics Engineering, Telkom University*
E-mail: ¹athallahabdullah@gmail.com,
²erwinbudisetiawan@telkomuniversity.ac.id

*Corresponding Author

Abstract—Background: The 2024 Indonesian Presidential Election is ideal for analyzing public sentiment on Twitter. Data collection began with crawling from the data source to create a dataset, which included 62,955 entries from Twitter, 126,673 entries from IndoNews, and a combined Tweet+IndoNews dataset totaling 189,628 entries. **Objective:** This study aims to explore sentiment using a hybrid model integrating Convolutional Neural Network (CNN) and Long Short-Term Memory (LSTM) methods, with feature expansion via Word2Vec optimized by a Genetic Algorithm (GA). **Methods:** The research evaluates the effectiveness of the hybrid CNN-LSTM model in analyzing sentiment from 2024 Indonesian Presidential Election tweets, aiming for higher accuracy and deeper insights compared to traditional methods. **Results:** The hybrid CNN-LSTM model, optimized with a Genetic Algorithm, significantly enhances accuracy, achieving the highest accuracy of 84.78% for the news data, marking a 3.59% increase. **Conclusion:** This study illustrates the innovative application of a hybrid CNN-LSTM model with Word2Vec feature expansion and Genetic Algorithm optimization for sentiment analysis in a national election context, demonstrating how advanced techniques can improve accuracy and efficiency in sentiment analysis.

Keywords—CNN-LSTM; Twitter; Election; Genetic Algorithm; Word2Vec

This is an open access article under the CC BY-SA License.



Corresponding Author:

Athallah Zacky Abdullah,
Department of Informatics Engineering,
Telkom University,
Email: athallahabdullah@gmail.com
Orchid ID: <https://orcid.org/0009-0000-7538-9530>



I. INTRODUCTION

The general election represents a fundamental expression of the people's sovereignty, providing a platform for citizens to assess and select members of the People's Representative Council. It also serves as a means of upholding and distributing the fundamental human rights of individuals [1]. Elections in Indonesia have been held since 1955 to elect members of the legislature. However, it was not until 2004 that the Indonesian people were given the opportunity to directly elect their president [2]. The presidential election is a democratic process designed to elect the President and Vice President. This election involves choosing the head of state through political parties [3].

Twitter is a social media platform where users frequently share their opinions on products, services, celebrities, events, and various other topics of interest. [4]. Social media platforms, including Twitter, are widely used for expressing sentiments and play a significant role in political campaigns, promoting social and developmental initiatives, and voicing opinions about elections. One of the earliest uses of social media for a political campaign occurred during the 2008 U.S. election [5]. With the rapid growth of the World Wide Web, people are increasingly using social media platforms, with a population of over 250 million, Indonesia has a vast number of social media users, making platforms like Twitter significant channels for expressing sentiments and influencing political and social discourse [6], [7].

Given its importance in understanding people's thoughts and attitudes, Twitter-based Sentiment Analysis (TSA) has garnered significant interest [8]. Sentiment analysis is the computational examination of individuals' opinions, attitudes, and emotions toward a particular entity [9]. It can also be viewed as a field encompassing machine learning, data mining, natural language processing, and computational linguistics, while also integrating elements of sociology and psychology [10].

Previous research on sentiment analysis using the CNN-LSTM algorithm showed very good performance compared to single CNN and LSTM models, achieving an accuracy of 91% [11]. Another study [12] The study revealed that the CNN-LSTM model achieved varying degrees of accuracy and F1-Score across different scenarios. Specifically, for split data, it reached an accuracy of 74.53% and an F1-Score of 74.29%; for maximum feature adjustment, the accuracy was 73.41% and the F1-Score was 73.00%; for feature expansion, the accuracy increased to 75.34% and the F1-Score to 75.13%; and for hyperparameter tuning, the accuracy was 75.75% with an F1-Score of 75.42%. These findings suggest that the CNN-LSTM model outperforms the individual CNN and LSTM approaches in several scenarios, particularly in feature expansion and hyperparameter tuning.

Additionally, the study demonstrated more accurate feature extraction using the Word2Vec and CNN methods. The proposed model achieved an accuracy of 99.07% for the training sample and 82.19% for the testing sample [13]. In the study, the use of genetic algorithm optimization enhanced the earlier GloVe-LSTM approach, achieving an accuracy rate of 87%. The best individual parameters included 111,170, 0.398, and 93, among others, with the highest fitness score being 0.8724 [14]. A comparison with leading methods in the field showed that this approach can achieve an accuracy of up to 96.984%. Additionally, the approach is automated, making it user-friendly even for those without in-depth knowledge of CNNs or GAs [15].

This research aims to analyze public sentiment regarding the 2024 General Elections in Indonesia through social media. To achieve this, a CNN-LSTM hybrid model will be employed for sentiment analysis, selected for its proven performance in previous study [12], [16]. The CNN-LSTM approach utilizes CNNs for feature extraction and LSTMs for capturing temporal dependencies, thereby enhancing sentiment analysis accuracy. The study will also incorporate genetic algorithm optimization and Word2Vec feature expansion to improve the model's precision and efficiency. While similar techniques have been explored, the innovative integration of the CNN-LSTM model with genetic algorithms and Word2Vec in this research is specifically tailored to the context of the 2024 elections. This unique combination aims to provide deeper insights into political discourse and advance sentiment analysis techniques, offering a more nuanced understanding of public opinion.

II. RESEARCH METHOD

This section outlines the flow used in the research, which involves several key steps to collect, preprocess, and analyze data from Twitter. The research flow can be visualized in Figure 1.

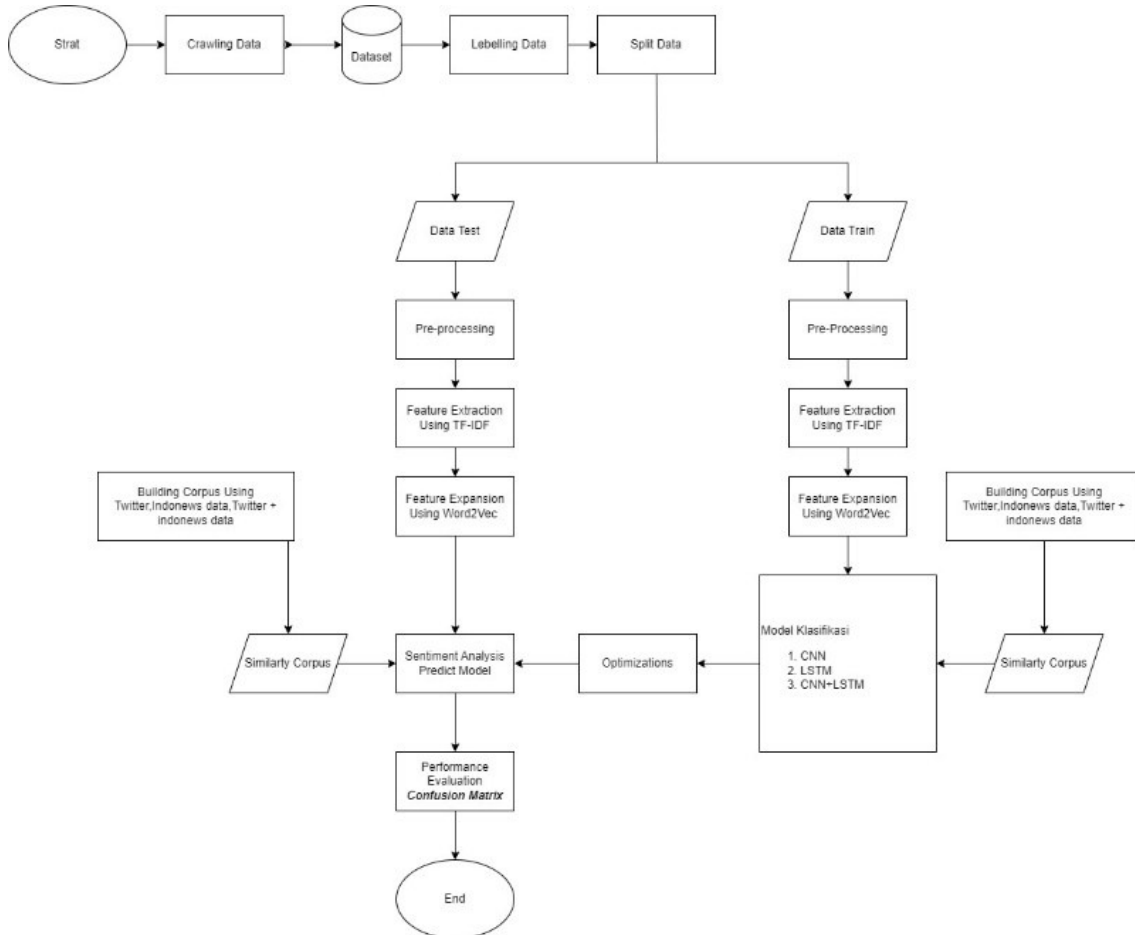

Fig 1. Flowchart Sentiment Analysis System

A. Crawling Data

Crawling is the initial step in data collection from the data source to create a dataset. In this study, data is collected from tweets on the Twitter platform related to the election. 62.955 data collected using the Python programming language and the Tweet library, with the resulting data directly stored in Comma Separated Values (CSV) format.

B. Labeling Data

Labeling data table 1 is the next step after the crawling process. The collected data will be manually labeled to make it easier to classify. The data labels are categorized into three groups: positive, neutral, and negative.

Table 1. Table labeled data

Label	Quantity
Positive	21.114
Neutral	20.644
Negative	21.197

C. Pre-Processing

The data collection process through crawling results in unstructured data that often contains noise. Therefore, a data preprocessing stage is carried out to reduce the noise level. This study applies five data preprocessing stages:

1. Data Cleaning:

At this stage, irrelevant attributes such as symbols, punctuation, numbers, URLs, and missing values are removed to improve data quality. The libraries used for this stage are re (Regular Expressions) for removing symbols, punctuation, and URLs, and pandas for handling missing values.

2. Case Folding:

All text is converted to lowercase to ensure consistency and reduce differences due to capitalization. This process can be performed using the `str.lower()` method in Python.

3. Stop Words:

Insignificant words, such as conjunctions and prepositions, are removed from the text using a stop words dictionary. The library commonly used for this stage is `nltk.corpus.stopwords` from the Natural Language Toolkit (NLTK).

4. Stemming:

Words are simplified by removing prefixes, suffixes, infixes, and certain prefix-suffix combinations to return the words to their base form. The libraries used for stemming are `nltk.stem.SnowballStemmer` for various languages and `Sastrawi.Stemmer` specifically for Indonesians.

5. Tokenization:

The text is split into separate words or tokens to facilitate further analysis. The libraries used for tokenization are `nltk.tokenize` from NLTK or `spacy` for more advanced and faster tokenization.

D. TF-IDF

TF-IDF (Term Frequency–Inverse Document Frequency) is a widely used weighting method in information retrieval and data mining [17]. Term Frequency (TF) determines how often a word appears in a document compared to the total word count. Inverse Document Frequency (IDF), on the other hand, evaluates the importance of a word by considering its occurrence across a set of documents [18]. The formula for calculating TF-IDF is:

$$tf = 0,5 + 0,5 \times \frac{tf}{\max(tf)} \quad (1)$$

$$df_t = \log\left(\frac{D}{df_t}\right) \quad (2)$$

$$w_{d,t} = tf_{d,t} \times i df_{d,t} \quad (3)$$

E. Word2Vec

Word2Vec is a deep learning technique rooted in the fundamental principles of neural networks, which serves as a feature expansion method. It incorporates bag-of-words and skip-gram models, effectively capturing the semantic relationships between words and thereby improving accuracy in sentiment classification tasks [19], [20].

F. Corpus Similarity

Gathering data from Twitter and multiple news outlets in Indonesia, followed by preprocessing, will form the corpus. This corpus will then be utilized to create a top-n rank dataset, where entries are ranked by their similarities. The top-n rank corpus will subsequently be employed for feature expansion [21]. In this research, three corpus (table 2) expansions were performed: Tweet, IndoNews, and Tweet+IndoNews, with the goal of extracting additional features to improve the machine learning model's performance.

Table 2. Table data corpus

Corpus Similarity	Quantity
Tweet	62.955
IndoNews	126.673
Tweet+Indonews	189.628

G. CNN

The Convolutional Neural Network (CNN), a regularized form of the Multi-Layer Perceptron, is classified as a deep feed-forward Artificial Neural Network. CNNs have gained significant popularity in recent years, particularly within the deep learning framework, due to their effectiveness. These models typically consist of convolutional, pooling, and fully connected layers. In the context of text classification (fig. 2), CNN models often employ an embedding layer to convert input text into vectors, facilitating more accurate classification outcomes [22], [23], [24].

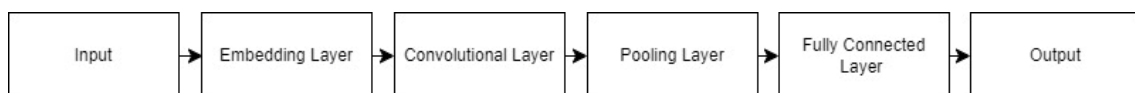

Fig 2. Simple CNN Structure.

H. LSTM

Long Short-Term Memory (LSTM) is a specialized recurrent neural network (RNN) architecture utilized in deep learning. Unlike traditional feedforward neural networks, LSTM

incorporates feedback connections, allowing it to maintain and utilize information over extended sequences. This capability enables LSTM to preserve important linkages and relevance, even when processing very long sequences [25]. LSTM has three main gates [26]. The Forget Gate (ft) decides which information should be discarded from the cell. The Input Gate (fig. 3) determines which information or input values will be used to update the memory cell. Lastly, the Output Gate (Ot) decides which values from the input and memory cell will be output.

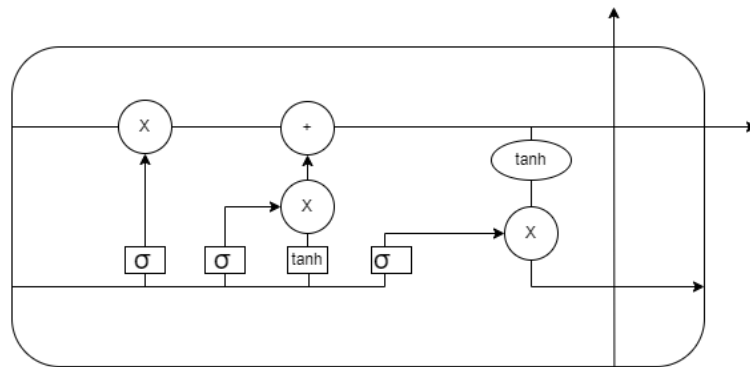

Fig 3. Simple LSTM Structure

I. CNN-LSTM

At this stage, the integration of two models, CNN-LSTM, is implemented, and the results are compared with the baseline CNN and LSTM models. CNN-LSTM neural network model can be effectively used for developing quantitative strategies, leading to higher returns compared to the basic Momentum strategy and the Benchmark index [16]. This experiment focuses on text classification, particularly in the context of sentiment analysis related to elections, involving information from the available tweet data. This approach allows for good adaptability in handling various types of inputs, creating a robust and versatile model for sequential information processing [12]. When the CNN processes the text features effectively, the resulting output is then fed into the LSTM model. In the LSTM model, each neuron, known as a cell, is equipped with three key mechanisms: the forget gate, the update gate, and the output gate [27].

- 1 **The forget gate** determines which information should be discarded from the cell state.
- 2 **The update gate** (often referred to as the input gate) decides which new information should be added to the cell state.
- 3 **The output gate** controls what part of the cell state should be output as the current state of the cell.

These mechanisms allow the LSTM model to manage and update its internal memory, enabling it to effectively capture long-term dependencies in the data.

J. Genetic Algorithms

Genetic Algorithm is a search technique inspired by natural selection processes, making it well-suited for solving complex optimization challenges. This optimization technique is employed to search for optimal solutions within a given search space [28], [29]. In GA optimization, the process involves several key steps, including Fitness Evaluation, Individual Selection, Crossover, Mutation, and subsequent fitness evaluation [30].

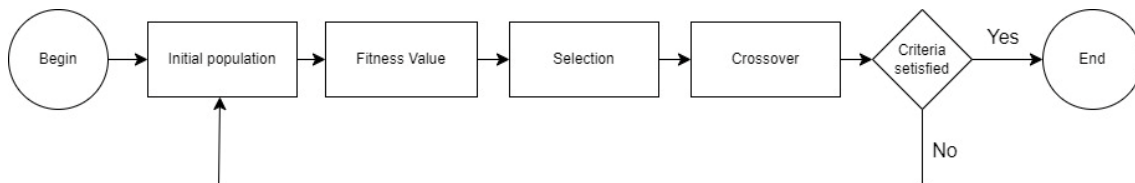

Fig 4. GA Structure

In this study (fig. 4), the Genetic Algorithm (GA) process starts with the creation of an initial population of candidate solutions. Each solution is evaluated based on its fitness, which indicates how well it solves the problem. Solutions with higher fitness are selected to act as parents and produce offspring through crossover. These offspring are then evaluated, and the process repeats until stopping criteria are met, such as achieving a desired fitness level or reaching a set number of iterations. When these criteria are satisfied, the process concludes, and the best solution found is chosen as the final result.

III. RESULT AND DISCUSSION

This study evaluates the effectiveness of a CNN-LSTM hybrid model, optimized using a Genetic Algorithm (GA), for sentiment analysis of tweets pertaining to Indonesia's 2024 General Election. Various experimental scenarios were conducted to assess the model's performance with and without additional features, as well as with different preprocessing techniques. Compared to previous research [12], the results show (table 3) that the CNN-LSTM hybrid model, when optimized with GA and expanded with Word2vec features, significantly improves sentiment analysis accuracy compared to using individual models.

Table 3. First Scenario: Base Mode

Split Ratio	Accuracy %		
	CNN	LSTM	CNN-LSTM
90:10	83.81	82.23	81.84
80:20	83.79	81.88	81.69
70:30	83.54	81.12	81.34
60:40	82.66	80.45	80.01

In the first scenario, the primary goal is to determine the optimal data split for testing purposes. Several data split strategies are applied, such as a 90% training and 10% testing ratio, along with other ratios. This analysis involves examining a table that displays the performance of three different models: CNN, LSTM, and CNN-LSTM, focusing on the evaluation of these models' prediction accuracy. The conclusion from this scenario (table 4) is that the data split ratio affects the models' accuracy, with the 90:10 ratio showing the best performance for the CNN model at 83.81%.

Table 4. Second Scenario

Max Feature	Accuracy %		
	CNN	LSTM	CNN-LSTM
2000	83.12(-0.82)	82.42(+0.23)	81.55(-0.35)
5000	83.43(-0.45)	82.89(+0.80)	82.78(+1.15)
10000	84.27(+0.55)	81.81(-0.51)	82.13(+0.35)
15000	84.39(+0.69)	81.91(-0.39)	82.08(+0.29)
20000	83.10(-0.85)	82.49(+0.32)	82.66(+1.00)

The results (table 5) indicate that the number of features significantly impacts model performance. For the CNN model, the highest accuracy was achieved with 15,000 features. The LSTM model performed best with 5,000 features, while the CNN-LSTM model showed the highest improvement with 5,000 features as well. This suggests that optimal feature numbers differ across models, with 15,000 features being most effective for CNN, and 5,000 features being most effective for both LSTM and CNN-LSTM.

Table 5. Third Scenario

N-Gram	Accuracy %		
	CNN	LSTM	CNN-LSTM
Unigram (1, 1)	84.39(+0.69)	82.89(+0.80)	82.78(+1.15)
Bigram (2, 2)	78.61(-6.20)	82.61(+0.46)	81.01(-1.01)
Trigram (3, 3)	70.85(-15.47)	81.62(-0.74)	81.83(-0.01)
Unigram + Bigram (1, 2)	83.91(+0.12)	82.78(+0.67)	82.73(+1.09)
Bigram + Trigram (2, 3)	78.32(-6.55)	81.66(-0.69)	80.38(-1.78)
Unigram + Bigram + Trigram (1, 3)	83.49(-0.38)	82.92(+0.84)	82.10(+0.32)

In the third scenario (table 6-8), the research focused on implementing TF-IDF to identify N-Grams, with the goal of achieving the highest accuracy. The conclusion from this scenario is that unigrams provide the best accuracy compared to bigrams and trigrams, as well as their combinations.

Table 6. Forth Scenario CNN

Rank	Accuracy %		
	Tweet	News	Tweet + News
TOP 1	84.30(+0.58)	83.75(-0.07)	84.26(+0.54)
TOP 5	84.32(+0.61)	84.33(+0.62)	84.10(+0.35)
TOP 10	83.90(+0.11)	84.10(+0.35)	84.46(+0.78)
TOP 15	84.14(+0.39)	84.02(+0.25)	83.89(+0.10)

Table 7. Forth Scenario LSTM

Rank	Accuracy %		
	Tweet	News	Tweet + News
TOP 1	82.34(+0.13)	83.02(+0.96)	82.78(+0.67)
TOP 5	82.83(+0.73)	82.56(+0.40)	83.12(+1.08)
TOP 10	83.62(+1.69)	82.92(+0.84)	83.26(+1.25)
TOP 15	82.32(+0.11)	82.73(+0.61)	82.59(+0.44)

Table 8. Forth Scenario CNN-LSTM

Rank	Accuracy %		
	Tweet	News	Tweet + News
TOP 1	82.78(+1.15)	82.27(+0.53)	82.56(+0.88)
TOP 5	82.80(+1.17)	82.32(+0.59)	82.15(+0.38)
TOP 10	82.17(+0.40)	83.07(+1.50)	82.39(+0.67)
TOP 15	82.68(+1.03)	83.00(+1.42)	82.42(+0.71)

In the fourth scenario (table 9), this study focused on sentiment analysis using tweet, news, and their combination (tweet + news) with CNN, LSTM, and hybrid CNN-LSTM models. The results indicated that the tweet + news combination performed best across all models at the TOP 10 ranking, achieving accuracies of 84.46% for CNN, 83.26% for LSTM, and 82.39% for hybrid CNN-LSTM. This underscores how integrating diverse corpora significantly enhances sentiment prediction accuracy, particularly in analyzing public opinion during events such as elections.

Table 9. Fith Scenario CNN+LSTM

Rank	Accuracy %		
	Tweet	News	Tweet + News
TOP 1	83.80(+2.29)	84.78(+3.59)	84.60(+3.37)
TOP 5	84.21(+2.90)	84.37(+3.09)	84.01(+2.65)
TOP 10	83.51(+2.40)	83.35(+1.84)	83.23(+1.70)
TOP 15	83.49(+2.02)	83.46(+1.98)	83.17(+1.63)

In the final scenario, the experiment aimed to enhance accuracy by using a Genetic Algorithm (GA) with the hybrid CNN-LSTM model. The results show that the integration of GA significantly improved the accuracy across different corpus rankings. Specifically, the news corpus achieved the highest accuracy increase at TOP 1 with a +3.59% improvement, followed by the combined corpus (Tweet + News) with a +3.37% improvement. The tweet corpus also showed a substantial improvement at +2.29%. Similar trends were observed at other ranking levels, with the news corpus consistently outperforming the others. The combined corpus also showed notable improvements, though slightly less than the news corpus. Overall, the use of GA with the CNN-LSTM hybrid model significantly enhanced the accuracy of sentiment analysis, particularly when using the news corpus (table 10).

Table 10. Statistical Significance Tests in Various Scenarios

	S1→S2	S2→S3	S3→S4	S4→S5	S1→S5
Z-Value	6.658	nan	1.872	2.630	3.575
P-Value	2.771	nan	0.061	0.008	0.003
Significant?	TRUE	FALSE	FALSE	TRUE	TRUE

The study assessed the significance of accuracy changes in each scenario using Z-values and P-values for statistical testing. Changes were considered highly significant if Z-Value > 1.96 and P-Value < 0.01, significant if Z-Value > 1.96 and P-Value < 0.05, and insignificant otherwise. Table 1 presents the statistical significance test results for all scenarios. According to the table, changes in scenarios S2→S3 and S3→S4 did not exhibit statistically significant improvements as their Z-Values and P-Values did not meet the significance criteria (Z-Value > 1.96 and P-Value < 0.05). However, changes from scenarios S1→S2, S4→S5, and S1→S5 showed significant improvements with Z-Values and P-Values indicating statistical significance. This indicates that these transitions between scenarios can significantly enhance performance based on the given confidence level and criteria. This research underscores the importance of employing hybrid models and feature optimization in social media sentiment analysis. By leveraging relevant data and appropriate feature extraction techniques, models can effectively capture sentiment and provide more accurate insights. In the context of the 2024 General Election, this approach can be instrumental in understanding public opinion and evolving political dynamics, offering a valuable tool for researchers and policymakers.

IV. CONCLUSION

This study evaluates a CNN-LSTM hybrid model optimized with a Genetic Algorithm (GA) for sentiment analysis of 62,955 tweets related to Indonesia's 2024 Presidential Election. Using

expanded corpora—Tweet (62,955), IndoNews (126,673), and combined (189,628)—the CNN model achieved 83.81% accuracy with a 90:10 split. Optimal feature counts were 15,000 for CNN and 5,000 for LSTM/CNN-LSTM. Unigrams outperformed bigrams/trigrams, and combining tweet and news data improved sentiment prediction, with GA-optimized CNN-LSTM reaching 84.78% accuracy (+3.59%). While effective, limitations include dataset scope, timeframe constraints, overlooked sentiment nuances, election-specific results, and model complexity, suggesting further refinement.

Author Contributions: *Athallah Zacky Abdullah*: was responsible for drafting the original manuscript, curating data, performing formal analysis, and conducting experiments. *Erwin Budi Setiawan*: contributed to the conceptualization, methodology, and review for editing of the manuscript.

All authors have read and agreed to the published version of the manuscript.

Funding: This research received no specific grant from any funding agency.

Conflicts of Interest: The authors declare no conflict of interest.

Data Availability: You can contact author's email whenever you need the explanation for this Research

Informed Consent: There were no human subjects.

Animal Subjects: There were no animal subjects.

ORCID:

Athallah Zacky Abdullah: <https://orcid.org/0009-0000-7538-9530>

Erwin Budi Setiawan: <http://orcid.org/0000-0002-2121-8776>

REFERENCES

- [1] A. I. Purnamasari, S. Sulbadana, S. Supriyadi, and A. Kasim, "Redesigning: Handling Of Indonesian Election Violations Abroad To Realizing Quality 2024 Elections," *Fiat Justisia: Jurnal Ilmu Hukum*, vol. 17, no. 1, pp. 75–92, Mar. 2023, doi: 10.25041/fiatjustisia.v17no1.2637.
- [2] W. Budiharto and M. Meiliana, "Prediction and analysis of Indonesia Presidential election from Twitter using sentiment analysis," *J Big Data*, vol. 5, no. 1, Dec. 2018, doi: 10.1186/s40537-018-0164-1.
- [3] L. Damayanti and K. M. Lhaksmana, "Sentiment Analysis of the 2024 Indonesia Presidential Election on Twitter," *Jurnal dan Penelitian Teknik Informatika*, vol. 8, no. 2, 2024, doi: 10.33395/v8i2.13379.
- [4] A. Giachanou and F. Crestani, "Like it or not: A survey of Twitter sentiment analysis methods," Jun. 01, 2016, *Association for Computing Machinery*. doi: 10.1145/2938640.
- [5] H. N. Chaudhry *et al.*, "Sentiment analysis of before and after elections: Twitter data of U.S. election 2020," *Electronics (Switzerland)*, vol. 10, no. 17, Sep. 2021, doi: 10.3390/electronics10172082.

- [6] A. Fuadi, "Social media power for protest in Indonesia: The Yogyakarta's #gejayanmemanggil case study," *Jurnal Studi Komunikasi (Indonesian Journal of Communications Studies)*, vol. 4, no. 3, p. 541, Nov. 2020, doi: 10.25139/jsk.v4i3.2438.
- [7] A. Sarlan, C. Nadam, and S. Basri, "Twitter sentiment analysis," in *Conference Proceedings - 6th International Conference on Information Technology and Multimedia at UNITEN: Cultivating Creativity and Enabling Technology Through the Internet of Things, ICIMU 2014*, Institute of Electrical and Electronics Engineers Inc., 2014, pp. 212–216. doi: 10.1109/ICIMU.2014.7066632.
- [8] Y. Wang, J. Guo, C. Yuan, and B. Li, "Sentiment Analysis of Twitter Data," Nov. 01, 2022, MDPI. doi: 10.3390/app122211775.
- [9] W. Medhat, A. Hassan, and H. Korashy, "Sentiment analysis algorithms and applications: A survey," *Ain Shams Engineering Journal*, vol. 5, no. 4, pp. 1093–1113, 2014, doi: <https://doi.org/10.1016/j.asej.2014.04.011>.
- [10] J. Cui, Z. Wang, S. B. Ho, and E. Cambria, "Survey on sentiment analysis: evolution of research methods and topics," *Artif Intell Rev*, vol. 56, no. 8, pp. 8469–8510, Aug. 2023, doi: 10.1007/s10462-022-10386-z.
- [11] A. U. Rehman, A. K. Malik, B. Raza, and W. Ali, "A Hybrid CNN-LSTM Model for Improving Accuracy of Movie Reviews Sentiment Analysis," *Multimed Tools Appl*, vol. 78, no. 18, pp. 26597–26613, Sep. 2019, doi: 10.1007/s11042-019-07788-7.
- [12] M. N. Ibnu Sina and E. B. Setiawan, "Stock Price Correlation Analysis with Twitter Sentiment Analysis Using The CNN-LSTM Method," *sinkron*, vol. 8, no. 4, pp. 2190–2202, Oct. 2023, doi: 10.33395/sinkron.v8i4.12855.
- [13] A. K. Sharma, S. Chaurasia, and D. K. Srivastava, "Sentimental Short Sentences Classification by Using CNN Deep Learning Model with Fine Tuned Word2Vec," in *Procedia Computer Science*, Elsevier B.V., 2020, pp. 1139–1147. doi: 10.1016/j.procs.2020.03.416.
- [14] R. T. Setiawan and E. B. Setiawan, "Sentiment Analysis of BBCA Stock Price on Twitter Data Using LSTM and Genetic Algorithm Optimization," *sinkron*, vol. 8, no. 4, pp. 2479–2489, Oct. 2023, doi: 10.33395/sinkron.v8i4.12825.
- [15] D. Dangi, A. Bhagat, and D. K. Dixit, "Sentiment analysis on social media using genetic algorithm with CNN," *Computers, Materials and Continua*, vol. 70, no. 3, pp. 5399–5419, 2022, doi: 10.32604/cmc.2022.020431.
- [16] S. Liu, C. Zhang, and J. Ma, "CNN-LSTM Neural Network Model for Quantitative Strategy Analysis in Stock Markets," Jun. 2017, pp. 198–206. doi: 10.1007/978-3-319-70096-0_21.
- [17] L. Hao, C. Xi, and L. xiao, "A Study of the Application of Weight Distributing Method Combining Sentiment Dictionary and TF-IDF for Text Sentiment Analysis," *IEEE Access*, vol. 10, p. 1, Aug. 2022, doi: 10.1109/ACCESS.2022.3160172.
- [18] R. Ahuja, A. Chug, S. Kohli, S. Gupta, and P. Ahuja, "The impact of features extraction on the sentiment analysis," in *Procedia Computer Science*, Elsevier B.V., 2019, pp. 341–348. doi: 10.1016/j.procs.2019.05.008.
- [19] S. Khomsah, "Sentiment Analysis On YouTube Comments Using Word2Vec and Random Forest," *Telematika*, vol. 18, p. 61, Jul. 2021, doi: 10.31315/telematika.v18i1.4493.
- [20] C. Zhang, X. Wang, S. yu, and Y. Wang, "Research on Keyword Extraction of Word2vec Model in Chinese Corpus," Aug. 2018, pp. 339–343. doi: 10.1109/ICIS.2018.8466534.
- [21] I. Gde Bagus Janardana Abasan and E. B. Setiawan, "Empowering hate speech detection: leveraging linguistic richness and deep learning," *Bulletin of Electrical Engineering and Informatics*, vol. 13, no. 2, pp. 1371–1382, Apr. 2024, doi: 10.11591/eei.v13i2.6938.
- [22] H. Khotimah, E. Setiawan, and I. Kurniawan, "Implementation Information Gain Feature Selection for Hoax News Detection on Twitter using Convolutional Neural Network (CNN)," Aug. 2020. doi: 10.34818/indojc.2021.5.3.506.

- [23] Zulqarnain, R. Ghazali, Y. Mazwin, and M. Rehan, "A comparative review on deep learning models for text classification," *Indonesian Journal of Electrical Engineering and Computer Science*, vol. 19, Aug. 2020, **doi:** 10.11591/ijeecs.v19.i1.pp325-335.
- [24] A. Yadav and D. K. Vishwakarma, "Sentiment analysis using deep learning architectures: a review," *Artif. Intell. Rev.*, vol. 53, no. 6, pp. 4335–4385, Aug. 2020, **doi:** 10.1007/s10462-019-09794-5.
- [25] S. Seo, C. Y. Kim, H. Kim, K. Mo, and P. Kang, "Comparative Study of Deep Learning-Based Sentiment Classification," *IEEE Access*, vol. PP, p. 1, Aug. 2020, **doi:** 10.1109/ACCESS.2019.2963426.
- [26] S. I. Putri, E. B. Setiawan, and Y. Sibaroni, "JURNAL MEDIA INFORMATIKA BUDIDARMA Aspect-Based Sentiment Analysis on Twitter Using Long Short-Term Memory Method," 2023, **doi:** 10.30865/mib.v5i1.2293.
- [27] H. Zhou, "Research of Text Classification Based on TF-IDF and CNN-LSTM," in *Journal of Physics: Conference Series*, IOP Publishing Ltd, Jan. 2022. **doi:** 10.1088/1742-6596/2171/1/012021.
- [28] A. F. Siagian, G. J. Yanris, and S. P. Sitorus, "Applying genetic algorithm for optimization income value," *Sinkron*, vol. 7, no. 2, pp. 753–759, May 2022, **doi:** 10.33395/sinkron.v7i2.11431.
- [29] P. Rani, J. Shokeen, A. Majithia, A. Agarwal, A. Bhatghare, and J. Malhotra, "Designing an LSTM and Genetic Algorithm-based Sentiment Analysis Model for COVID-19," 2022, pp. 209–216. **doi:** 10.1007/978-981-16-6285-0_17.
- [30] I. R. Illahi and E. B. Setiawan, "Sentiment Analysis of the 2024 Indonesian Presidential Election using Fasttext Feature Expansion and Recurrent Neural Network (RNN) with Genetic Algorithm Optimization," *Intl. Journal on ICT*, vol. 10, no. 1, pp. 78–89, 2024, **doi:** 10.21108/ijoiict.v10i1.905.